

### Description

The SR3.3 is a low capacitance TVS diode array, utilizing leading monolithic silicon technology to provide fast response time and low ESD clamping voltage, making this device an ideal solution for protecting sensitive semiconductor components from damage. The SR3.3 complies with the IEC 61000-4-2(ESD) standard with  $\pm 30\text{kV}$  air and  $\pm 30\text{kV}$  contact discharge. It is assembled into a lead-free SOT-143 package. It is designed to protect components which are connected to high speed interfaces and transmission lines from voltage surges.

### Mechanical Characteristics

- ◆ Package: SOT-143
- ◆ Lead Finish: Matte Tin
- ◆ Case Material: "Green" Molding Compound.
- ◆ UL Flammability Classification Rating 94V-0
- ◆ Moisture Sensitivity: Level 3 per J-STD-020
- ◆ Terminal Connections: See Diagram Below
- ◆ Marking Information: See Below

### Features

- ◆ 150W peak pulse power(8/20 $\mu\text{s}$ )
- ◆ Ultra low leakage: nA level
- ◆ Operating voltage: 3.3V
- ◆ Low capacitance for high-speed data line
- ◆ Low clamping voltage
- ◆ Complies with following standards:
  - IEC 61000-4-2 (ESD) immunity test  
Air discharge:  $\pm 30\text{kV}$   
Contact discharge:  $\pm 30\text{kV}$
  - IEC61000-4-4 (EFT) 40A (5/50ns)
  - IEC61000-4-5 (Lightning) 10A (8/20 $\mu\text{s}$ )
- ◆ RoHS Compliant

### Applications

- ◆ Video Line Protection
- ◆ Wireless Systems
- ◆ Portable Instrumentation
- ◆ LAN/WAN equipment
- ◆ High-Speed Data Lines
- ◆ Multi-Protocol Serial Transceivers

### Dimensions and Pin Configuration

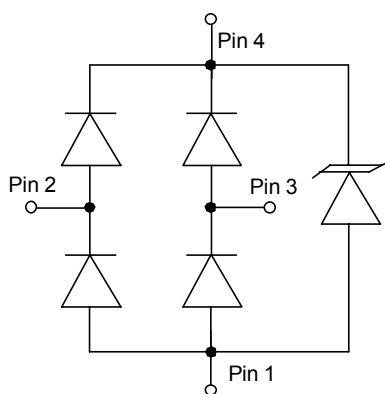

Circuit Diagram

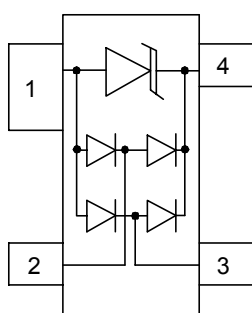

Pin Schematic

### Marking Information

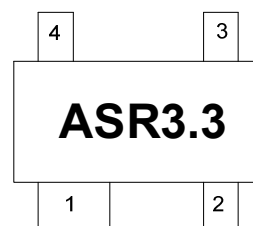

### Ordering Information

Part Number	Marking	Packaging	Reel Size
SR3.3	ASR3.3	3000/Tape & Reel	7 inch

### **Absolute Maximum Ratings ( $T_A=25^\circ\text{C}$ unless otherwise specified)**

Parameter	Symbol	Value	Unit
Peak Pulse Power(8/20 $\mu\text{s}$ )	Ppk	150	W
Peak Pulse Current(8/20 $\mu\text{s}$ )	I <sub>PP</sub>	10	A
ESD per IEC 61000-4-2 (Air)	V <sub>ESD</sub>	$\pm 30$	kV
ESD per IEC 61000-4-2 (Contact)		$\pm 30$	
Operating Temperature Range	T <sub>J</sub>	-55 to +125	$^\circ\text{C}$
Storage Temperature Range	T <sub>stg</sub>	-55 to +150	$^\circ\text{C}$

### **Electrical Characteristics ( $T_A=25^\circ\text{C}$ unless otherwise specified)**

Parameter	Symbol	Min	Typ	Max	Unit	Test Condition
Reverse Working Voltage	V <sub>RWM</sub>			3.3	V	
Breakdown Voltage	V <sub>BR</sub>	3.5			V	I <sub>T</sub> = 2 $\mu\text{A}$
Reverse Leakage Current	I <sub>R</sub>			0.5	$\mu\text{A}$	V <sub>RWM</sub> = 3.3V
Clamping Voltage	V <sub>C</sub>			7	V	I <sub>PP</sub> = 1A (8 x 20 $\mu\text{s}$ pulse)
Clamping Voltage	V <sub>C</sub>			15	V	I <sub>PP</sub> = 10A (8 x 20 $\mu\text{s}$ pulse)
Junction Capacitance	C <sub>J</sub>			3.5	pF	V <sub>R</sub> = 0V, f = 1MHz, between I/O pins and GND
Junction Capacitance	C <sub>J</sub>			2	pF	V <sub>R</sub> = 0V, f = 1MHz, between I/O pins

**Typical Performance Characteristics (TA=25°C unless otherwise Specified)**

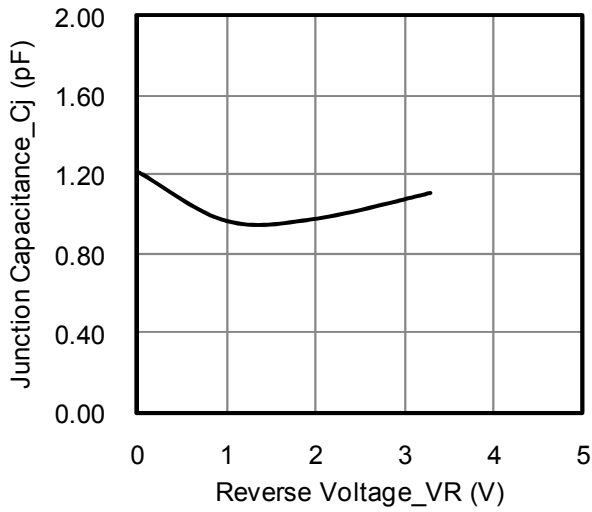

**Junction Capacitance vs. Reverse Voltage**

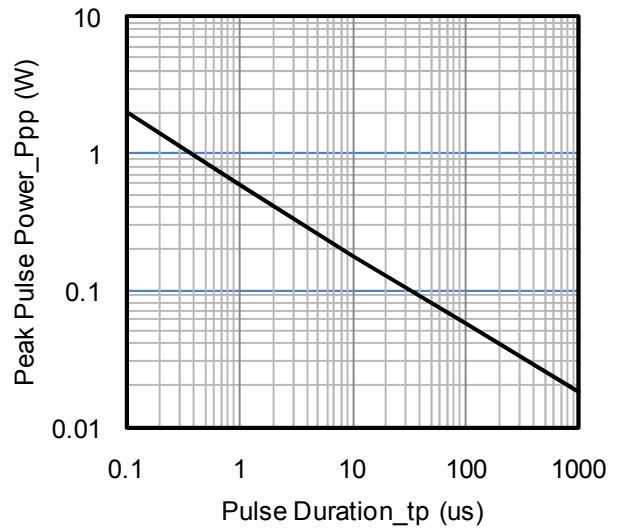

**Peak Pulse Power vs. Pulse Time**

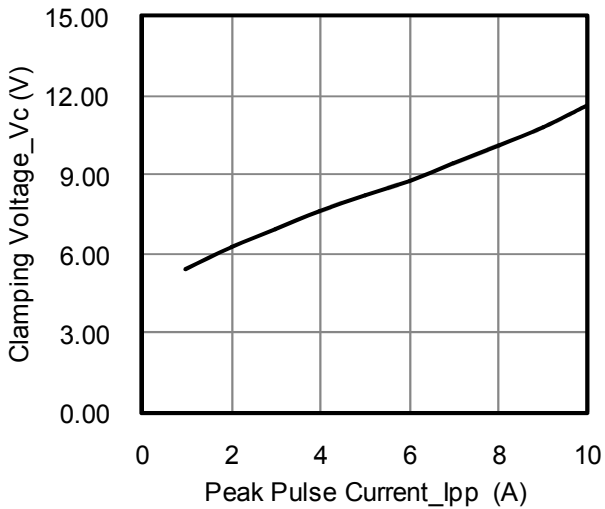

**Clamping Voltage vs. Peak Pulse Current**

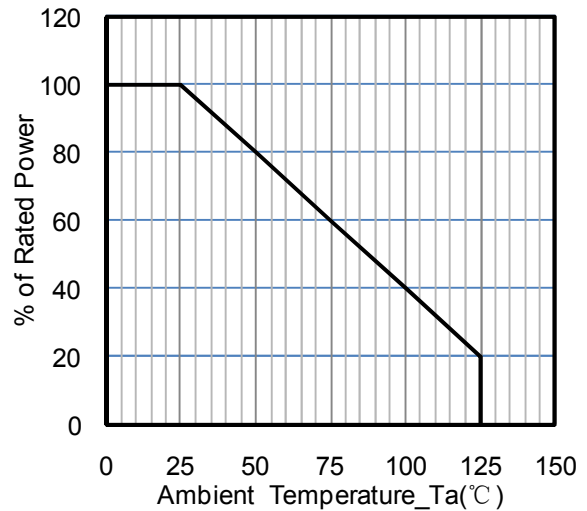

**Power Derating Curve**

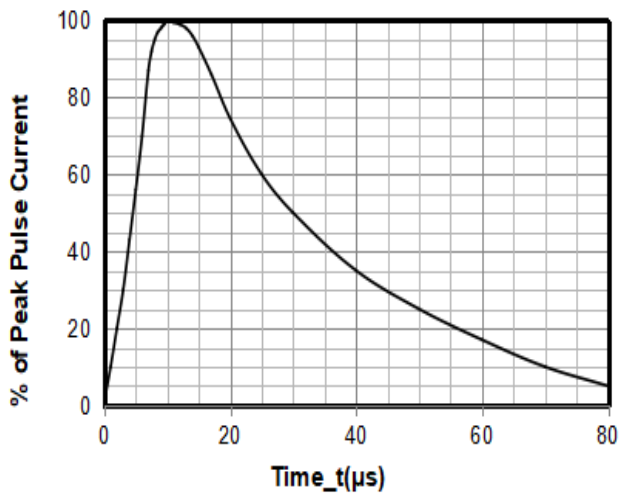

**8 X 20uS Pulse Waveform**

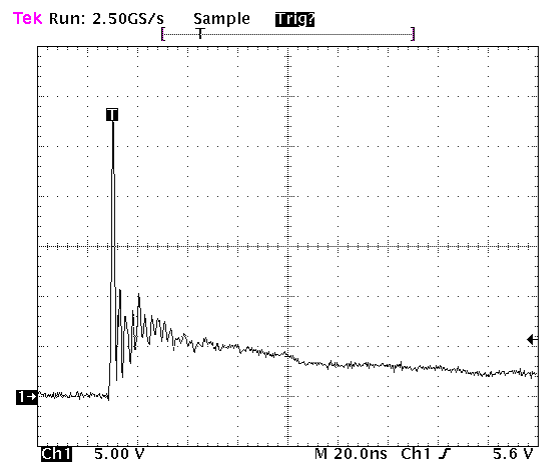

**ESD Clamping Voltage**

8 kV Contact per IEC61000-4-2

### SOT-143 Package Outline Drawing

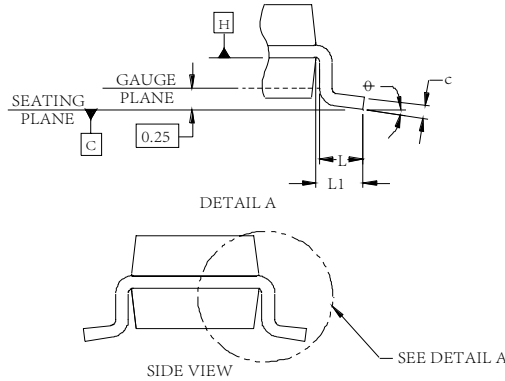
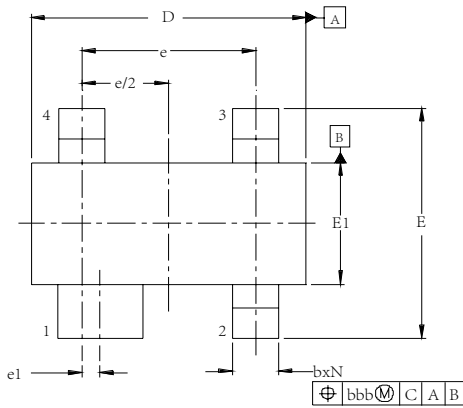

DIM	DIMENSIONS					
	INCHES			MILLIMETERS		
	MIN	NOM	MAX	MIN	NOM	MAX
A	.031	-	.048	0.80	-	1.22
A1	.000	-	.006	0.013	-	0.15
A2	.029	.035	.042	0.75	0.90	1.07
b	.011	-	.020	0.30	-	0.51
b1	.029	-	.037	0.76	-	0.94
c	.003	-	.008	0.08	-	0.20
D	.110	.114	.120	2.80	2.90	3.04
E	.082	.093	.104	2.10	2.37	2.64
E1	.047	.051	.055	1.20	1.30	1.40
e	.075			1.92 BSC		
e1	.008			0.20 BSC		
L	.015	.020	.024	0.40	0.50	0.60
L1	(0.021)			(0.54)		
N	4			4		
⊕	0°	-	8°	0°	-	8°
aaa	.006			0.15		
bb b	.008			0.20		
ccc	.004			0.10		

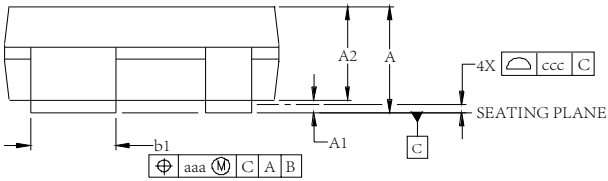

### Suggested Land Pattern

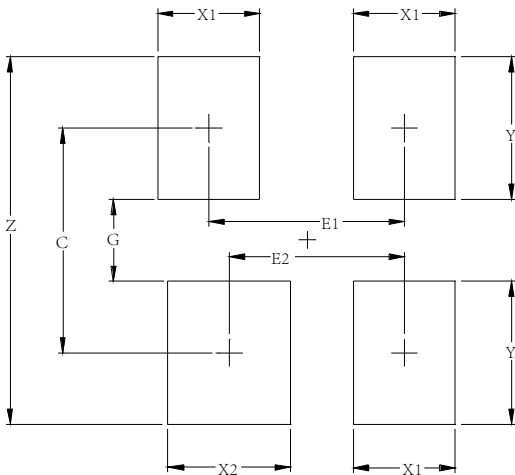

SYM	DIMENSIONS	
	MILLIMETERS	INCHES
C	2.20	0.087
E1	1.92	0.076
E2	1.72	0.068
G	0.80	0.031
X1	1.00	0.039
X2	1.20	0.047
Y	1.40	0.055
Z	3.60	0.141

### Contact Information

Changzhou D-first Electronics CO.,Ltd.  
 www.first-electronic.com  
 Email: xhf@first-electronic.cn  
 Phone: +86 (0519) 8817 1671